

CBNA 双联齿轮泵

CBNA HI/LOW GEAR PUMPS

简介 General Description

CBNA 双联齿轮泵是由一个大排量低压力齿轮泵和一个小排量高压力齿轮泵组成，包括前盖、壳体 and 泵体，在泵体上装有单向阀，前盖上装有溢流阀。当双联泵工作压力小于溢流阀开启压力时，两个齿轮泵同时输出液压油，当工作压力高于溢流阀开启压力时，只有小排量齿轮泵输出高压液压油，从而减少功率损耗。CBN 系列双联齿轮泵广泛地应用于劈柴机、压力机和机床中。

The CBNA gear pump consists of a big displacement, low pressure pump and a small displacement, high pressure pump, a check valve as well as a relief valve. When working at the pressure lower than the relief pressure, both big and small pump output flow. While working at a higher pressure, only small pump outputs flow, which highly reduces the power consumption. The CBN pump is widely used in log splitter, press, machine tools.

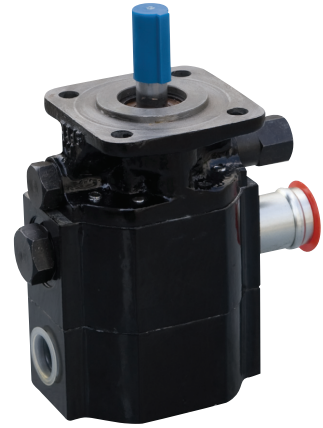

型谱 Order Code

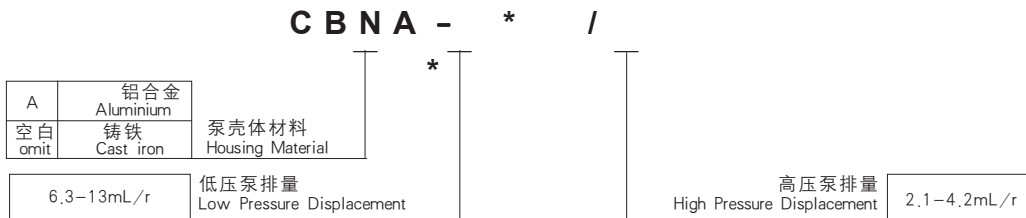

外形尺寸图 Outline Dimension

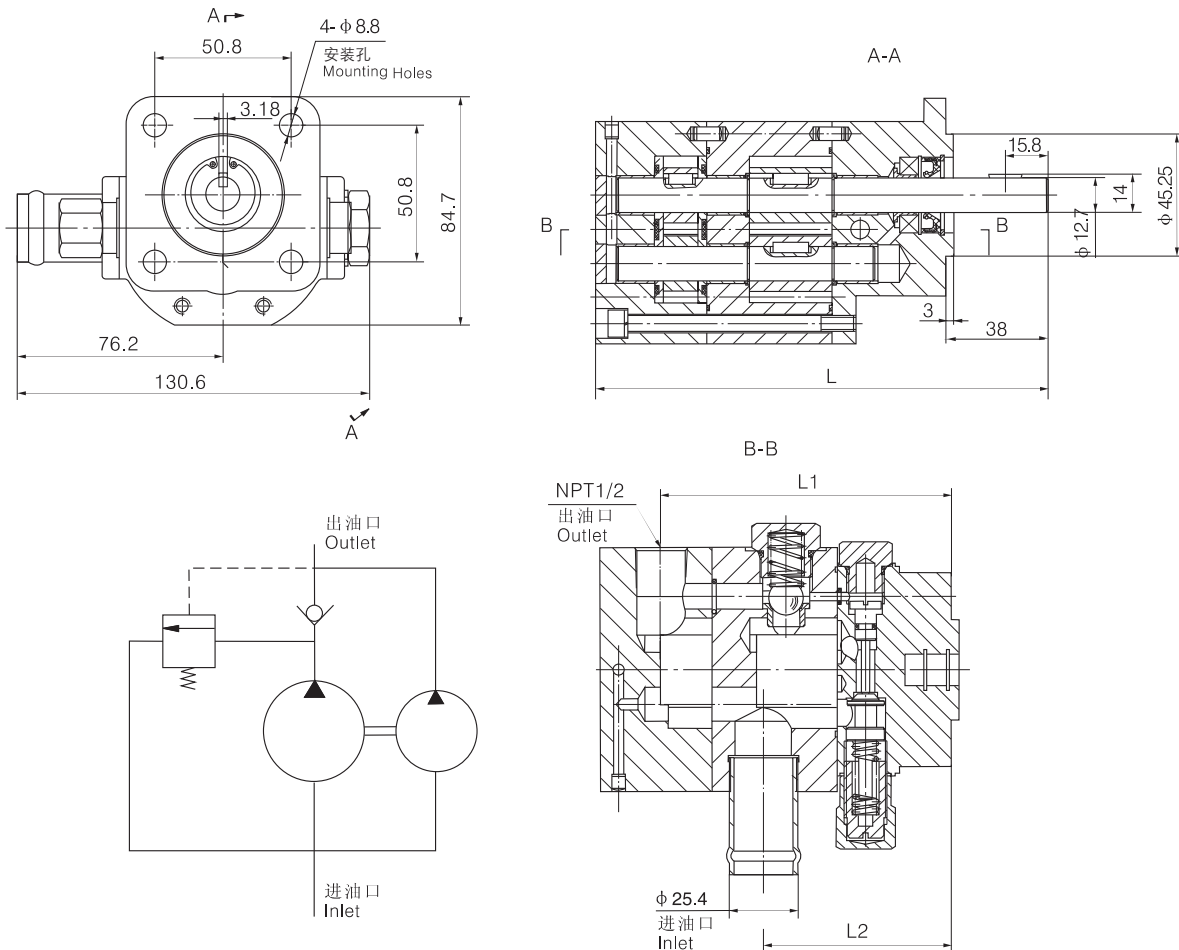

Model 型号	流量 Flow L/min (GPM)	排量 Displacement (ml/r)		压力 Pressure(MPa)		Speed 转速 (RPM)	尺寸 Dimension (mm)		
		高压泵 Hi Pre.	低压泵 Low Pre.	溢流阀 Unload Preset:	工作压力 Work		L	L1	L2
CBNA-6.3/2.1	30(8)	2.1	6.3	范围: 2.8-6.3 Range: 2.8-6.3 初设值: 4.5 Preset: 4.5	21	3600	154.2	95.2	61.2
CBNA-6.3/3.0	33.5(8.5)	3.0	6.3				157.8	95.2	61.2
CBNA-6.3/3.6	35.5(9)	3.6	6.3				159.9	99.6	61.6
CBNA-8.8/1.6	37.4(10)	1.6	8.8				162	103.6	69.6
CBNA-8.8/2.1	39(10)	2.1	8.8				162.7	103.6	69.6
CBNA-8.8/3.0	42(10.5)	3.0	8.8				166.2	103.6	69.6
CBNA-8.8/3.6	44(11)	3.6	8.8				167.9	107.6	69.6
CBNA-8.8/4.2	46(11.5)	4.2	8.8				170.2	109.9	69.6
CBNA-10.9/2.1	46(12)	2.1	10.9				170.2	109.9	77.1
CBNA-10.9/3.0	50(12.5)	3.0	10.9				173.7	113.4	77.1
CBNA-10.9/3.6	50(13)	3.6	10.9				175.4	115.1	77.1
CBNA-10.9/4.2	52(13.5)	4.2	10.9				177.7	117.4	77.1
CBNA-13/3.0	58(15.4)	3.0	13				180.7	122.1	84.1
CBNA-13/4.2	62(16.4)	4.2	13				184.7	122.1	84.1

特性图 Performance Curve(@3600RPM,N46 Oil)

