

SP45103, SP45203  
& SP45303

# TOW-BEHIND LAWN ROLLER



## Instruction & Assembly

SAVE THESE INSTRUCTIONS FOR FUTURE REFERENCE

# Table of Contents

General Warnings and Rules .....	3
Controls and Features Identification.....	5
Assembly Instructions .....	6
Operation Instructions .....	7
Maintenance and Storage .....	8
Specification.....	9
Parts Drawing & Parts List .....	10

## **GENERAL WARNINGS**

### **READ and UNDERSTAND this manual completely before using Lawn Roller.**

Operator must read and understand all safety and warning information, operating instructions, maintenance and storage instructions before operating this equipment. Failure to properly operate and maintain the lawn roller could result in serious injury to the operator or bystanders.

#### **Operation Warnings**

- Do not at any time carry passengers, sit or stand on the lawn roller.
- Do not allow children to play on, stand upon or climb on the roller.
- Never attach a garden hose to the fill/drain hole when filling the roller.
- Do not exceed rated capacity – **36”/280lb, 48”/380lb & 60”/ 440lb**
- Always inspect the roller before using to assure it is in good working condition.
- Replace or repair damaged or worn parts immediately.
- Always check and tighten hardware and assembled parts before operation.
- Always disconnect equipment from towing vehicle when cleaning or servicing the unit.
- Avoid large holes and ditches when using the lawn roller.
- Be careful when operating on steep grades.
- Never use a roller up and down slopes, always work across or diagonally.
- Always operate at reduce speed in rough terrain, along creeks, ditches and on hillsides.
- Do not operate close to creeks, ditches and public highways.
- To avoid personal injury and/or equipment damage **DO NOT EXCEED 5 MPH.**
- Only tow with recommended vehicles (Lawn/Garden Tractors and ATVs).

#### **Crush and Cut Hazards**

- Always keep hands and feet clear from moving parts while operating the equipment.
- Always clear and keep work area clean when operating.
- Always wear safety gear, eye protection, gloves and work boots when operating the equipment.

### **WARNING**

The warnings, cautions, and instructions outlined in this instruction manual cannot cover all possible conditions or situations that may occur. It must be understood by the operator that common sense and caution are factors which cannot be built into this product and must be supplied by the operator.





### **WARNING**

This product can expose you to chemicals including lead and lead compounds which are known to the State of California to cause cancer and birth defects or other reproductive harm. For more information, go to [www.P65Warnings.ca.gov](http://www.P65Warnings.ca.gov).

#### **Assembly Is Required**

This product requires assembly before use. See “Assembly” section for instructions. Because of the weight and/or size of the lawn roller, it is recommended that another adult be present to assist with the assembly. **INSPECT ALL COMPONENTS** closely upon receipt to make sure no components are missing or damaged.

# Hazard Signal Word Definitions

	<p>This is the safety alert symbol. It is used to alert you to potential personal injury hazards. Obey all safety messages that follow this symbol to avoid possible injury or death.</p>
	<p><b>DANGER</b> indicates an imminently hazardous situation which, if not avoided, will result in death or serious injury.</p>
	<p><b>WARNING</b> indicates a potentially hazardous situation which, if not avoided, could result in death or serious injury.</p>
	<p><b>CAUTION</b> indicates a potentially hazardous situation which, if not avoided, may result in minor or moderate injury.</p>
	<p><b>CAUTION</b> used without the safety alert symbol indicates a potentially hazardous situation which, if not avoided, may result in property damage.</p>

## ABOUT YOUR TOW-BEHIND LAWN ROLLER

This lawn roller has a roughed steel frame and roller that is designed to smooth and level rough areas. The steel roller will accommodate either water or sand depending on the operators needs. When using water always drain and remove the fill/drain plug to avoid freezing. The lawn roller must be drained at temperatures below 32°F (0°C) to prevent damage. Never exceed the rated capacity listed for the size of roller you purchased.

- SP45103 - 36" Lawn Roller Max Capacity 280lb (127kg)
- SP45203 - 48" Lawn Roller Max Capacity 380lb (172.4kg)
- SP45303 - 60" Lawn Roller Max Capacity 440lb (199.6kg)

Technical specifications on the Lawn Roller are provided in the "Specifications" section of this manual.

## Controls and Features Identification

Read this owner's manual before operating the equipment. Familiarize yourself with the location and function of the controls and features. Save this manual for future reference.

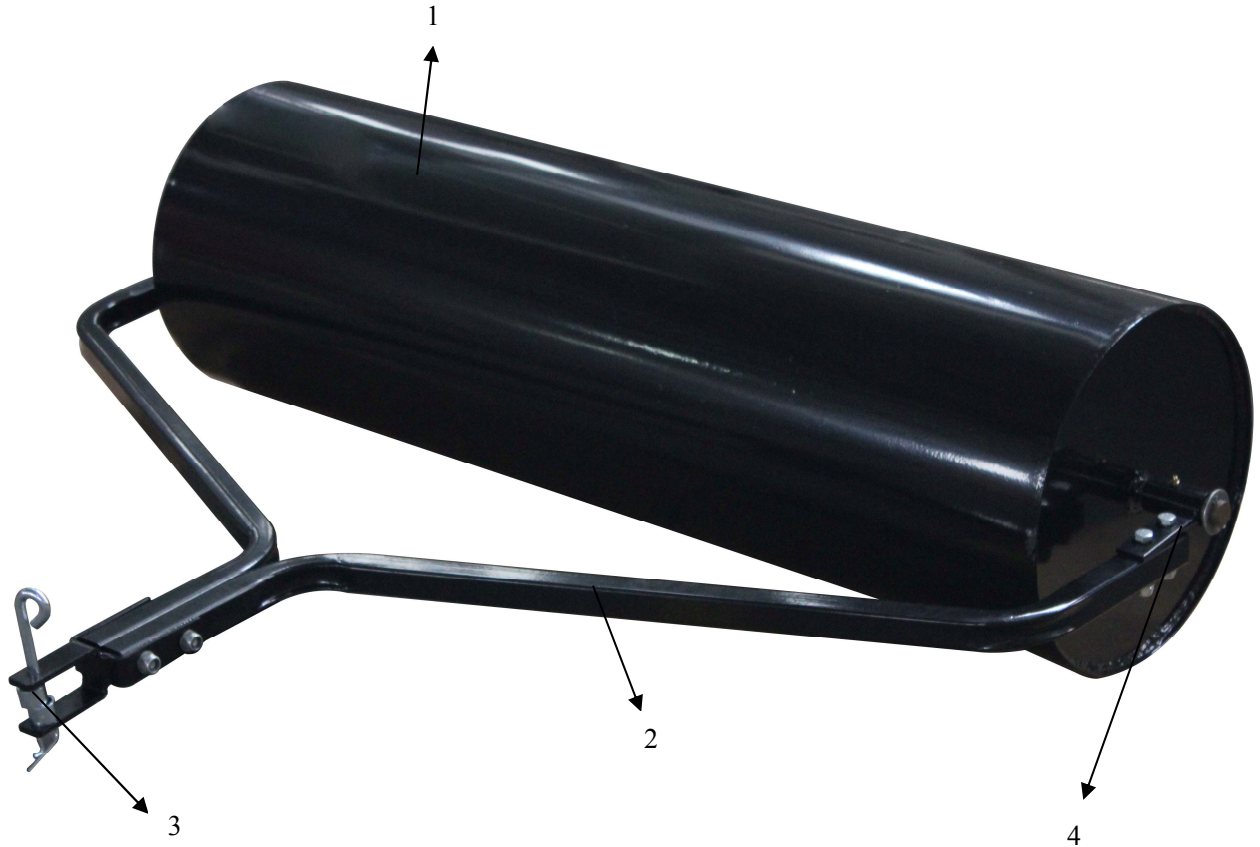

- 1) **Steel Roller** – Use water or sand do not exceed listed rated capacity.
- 2) **U- Roller Bracket** – Attaches to Steel Roller.
- 3) **Hitch** – Pin-type design use only with approve vehicles.
- 4) **Joint Bushing / Grease Fitting** – Grease before using.



## CAUTION

Read and follow all instructions for assembly and operation. Failure to properly assemble this equipment could result in serious injury to the user or bystanders, or cause equipment damage.

### LAWN ROLLER COMPONENT PARTS AND ASSEMBLE.

Take all parts out of the shipping crate and inspect components to ensure there are no missing pieces before starting to assemble the Lawn Roller follow the steps below.

#### TOOLS REQUIRED

- 10mm Wrench
- 14mm Wrench
- Large Adjustable Wrench (Fill/Drain Plug)

## Assembly Instructions

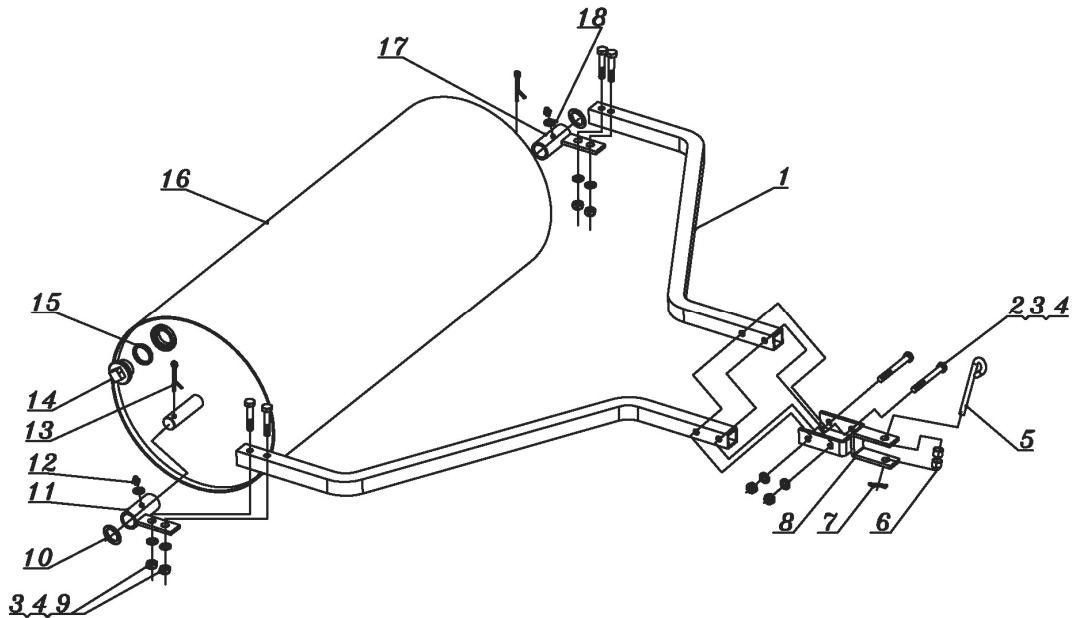

### Lawn Roller Assembly

1. Locate and layout all hardware and component parts.
2. Attach the U- Roller bracket (#1) to the joint bushing (#11& #17) using flat washer  $\varnothing 10$  (#3), nylon lock nut M10 (#4) and hex bolt M10x55 (#9).
3. Attach the joint bushing (#11& #17) to the axle of steel roller (#16), put a flat washer  $\varnothing 24$  (#10), then insert a cotter pin (#13).
4. Attach the hitch bracket (#8) to the U-Roller bracket (#1) using hex bolt M10x85 (#2), flat washer  $\varnothing 10$  (#3), nylon lock nut M10 (#4).
5. Insert hitch pin with 2 bushing (#6) and R pin (#7).
6. Tighten the grease fitting (#12) to the joint bushing (#11 & #17). Attach lock washer  $\varnothing 6$  (#18) in the middle of joint bushing and grease fitting.
7. Securely tighten all hardware before using.
8. Fill roller with water or sand do not exceed rated capacity.
9. Place Washer (15) over hole and secure with Fill/Drain Plug (14) and tighten.
10. Grease or oil bushings before using.

# Operation Instructions

## WARNING

Before using the lawn roller, review the instructions below and safety information before operating. Failure to follow these instructions may result in property damage or injury to the operator or bystanders.

### USING YOUR LAWN ROLLER

1. **DO NOT** exceed listed rated capacity of lawn roller.
2. **ALWAYS** reference approved vehicles (Lawn/Garden Tractors and ATVs) owner manuals for proper towing capacity and safe operation of your towing equipment.
3. **NEVER** attach a garden hose to the fill/drain hole when filling the roller. Dangerous pressure build up can occur.
4. **DO NOT** use if the lawn roller is damaged or worn as this may cause injury to the operator or bystanders.
5. **ALWAYS** use the lawn roller for its intended purpose.
6. **ONLY** use approved vehicles when towing the lawn roller (Lawn/Garden Tractors and ATVs).
7. **ALWAYS** make sure the lawn roller is secure and locked to the hitch of the approved vehicle before operating.
8. **ALWAYS** make sure that the tow vehicle and the combined weight of the operator **MUST BE** greater than the load of the lawn roller for proper control.
9. **DO NOT** use lawn roller on public highways or roads.
10. **NEVER** exceed 5mph when towing the lawn roller.
11. **ALWAYS** remember stopping distance will be greatly affected by added weight to the roller.
12. **DO NOT** make sharp turns that may cause the Lawn/Garden Tractor or ATV tires to rub against the lawn roller.
13. **ALWAYS** slow down before turning.

## WARNING

The lawn roller must be drained at temperatures below 32°F (0°C) to prevent damage.

When the roller is not being used always drain the water out and leave the fill/drain plug out.

# Maintenance and Storage



## WARNING

Improper maintenance and storage of the lawn roller may void your warranty.

## MAINTENANCE

- ALWAYS disconnect equipment from towing vehicle when cleaning or servicing the unit.
- After each use drain water and leave plug out.
- Rinse/dry the lawn roller after each use.
- Before using, grease axle and all moving parts as needed.
- Periodically check all fasteners for tightness.
- Annually clean and lightly lubricate parts.
- Use a glossy enamel spray paint to touch up scratched or worn painted metal surfaces.
- Never exceed the rated capacity of the lawn roller, it will do damage.

## IMPORTANT:

If a part needs replacement, only use parts that meet the manufacturer's specifications. Replacement parts that do not meet specifications may result in a safety hazard or poor operations.

## STORAGE

- Never leave water in the roller for extended periods of time.
- Remove fill/drain plug when storing.
- Always drain water from the roller to keep it from freezing.
- Before storing make sure the lawn roller is clean and dry for years of trouble free service.
- Store indoors or protected area during severe weather and winter months.



## Specifications

36" Roller Load Capacity.....	280lb (127kg)
48" Roller Load Capacity.....	380lb (172.4kg)
60" Roller Load Capacity.....	440lb (199.6kg)
36" Roller Dimensions (L x W).....	36" x 14"
48" Roller Dimensions (L x W).....	48" x 14"
60" Roller Dimensions (L x W).....	60" x 14"
Roller and Frame Material.....	Steel
Hitch Type.....	Universal Pin Style

## Parts Drawing & Parts List

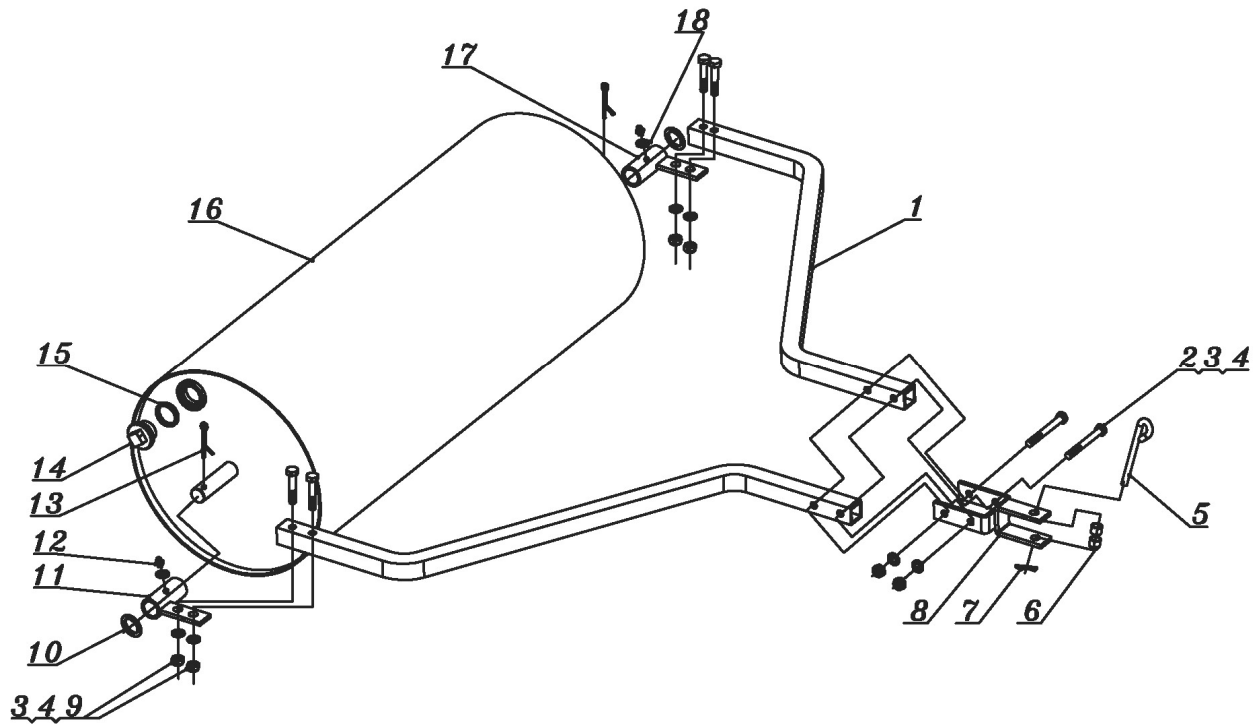

Ref#	Drawing No.	Description	Qty
1	TR3614/TR4814T6014-00001	U- Roller Bracket	2
2	9101-10085-DX	Hex Bolt M10x85	2
3	9301-10000-DX	Flat Washer Ø10	6
4	9206-10000-DX	Nylon Lock Nut M10	6
5	N870-00011	Hitch Pin	1
6	N280-00026	Bushing	2
7	N021-00004-DX	R Pin	1
8	TR3614-01000	Hitch Bracket	1
9	9101-10055-DX	Hex Bolt M10x55	4
10	T328-20004	Back Plate Ø43×Ø26×3	2
11	TR3614-03000	Joint Bushing (Right)	1
12	9701-06000	Grease Fitting	2
13	9404-05050-DX	Cotter Pin Ø5x50	2
14	N450-00001-DX	Fill/Drain Plug	1
15	N450-00002	Washer Ø40×Ø33×5	1
16	TR3614/TR4814/TR6014-01000	Steel Roller	1
17	TR3614-02000	Joint Bushing (Left)	1
18	9303-06000-DX	Lock Washer Ø6	2